

19" Drawer

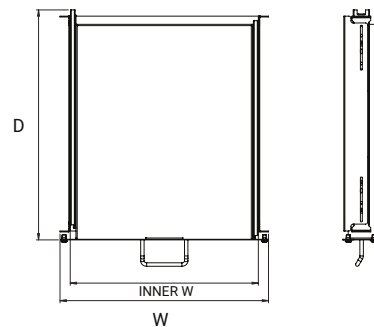

Material 1.5 mm Steel	Maximum Static Load 35 kg
Finish Electrostatic Powder Paint	Packaging One piece in a box

H (U)	D (mm)	W (mm)	Inner W (mm)	Weight kg	Part No
2U	500	483	435	6,36	CCA-X-1016
3U	500	483	435	9,54	CCA-X-1017

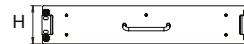

Fan Module for Wall Mount Enclosures



Operating Voltage AC 220 / 240 Volts 50/60 Hz	
Standards Conforms to IEC 297-1	Air Flow 85 / 97 CFM
Noise 42,2 / 44,5 dB (A)	Material 1,5 mm Steel
Fan Speed 2600 / 2900 rpm	Finish Electrostatic Powder Paint
Packaging One piece in a box	

H (mm)	D (mm)	W (mm)	Number of Fans	Weight kg	Part No
39	135	326	1	1,27	CWA-X-2001
39	135	326	2	1,80	CWA-X-2002

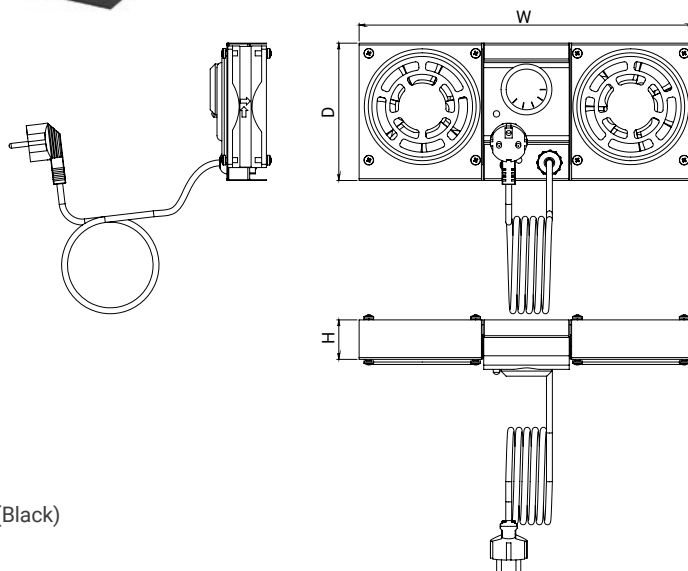

* X : Color code = 7: RAL 7035 (Grey); 9: RAL 9005 (Black)