



Multicom MUL-MS34-CH/K

Parts List, Connections, and Assembly

1. Kit Parts and Connections:

QTY	PART REF.	DESCRIPTION	CONNECT	
			FROM:	TO:
1	CHASSIS	CHASSIS	FROM:	TO:
1	J1	18" Jumper Cable	Switch A1	Chassis Input Hole 1 - Add Barrel Connector
1	J2	19" Jumper Cable	Switch A2	Chassis Input Hole 2 - Add Barrel Connector
1	J3	20" Jumper Cable	Switch A3	Chassis Input Hole 3 - Add Barrel Connector
1	J4	24" Jumper Cable	Switch B1	Switch C1
1	J5	26" Jumper Cable	Switch B2	Switch C2
1	J6	28" Jumper Cable	Switch B3	Switch C3
3	MMA	Male to Male Adapters	Switch A	Switch B
3	BARREL	Barrel Connectors	Other end of Jumpers J1, J2, J3	
15ea	W/N	Washers and Nuts	Secure Switches/Jumpers to Chassis	

2. Assembly:

STEP	PROCEDURE
1	Remove lid
2	Connect: Jumpers J1 to A1, J2 to A2, J3 to A3 - Add Barrel Connector to other end of Jumpers
3	Connect: Jumpers J4 to B1, J5 to B2, J6 to B3
4	Attach Switch A to Switch B using MMAs
5	Insert Barrel Connector on Jumper J1 into Chassis Input Hole 1. Secure with W/N.
6	Insert Switches A and B into Chassis with Jumper J1 under MMAs and between Switches A and B. Secure with W/Ns.
7	Insert Barrel Connectors on Jumpers J2 and J3 into Chassis Input Holes 2 and 3. Secure with W/Ns.
8	Connect: Jumpers J4 to C1, J5 to C2, J6 to C3
9	Insert Switch C into Chassis. Secure with W/Ns.
10	Ensure all connections to Multiswitches and Chassis are secure. Replace lid.

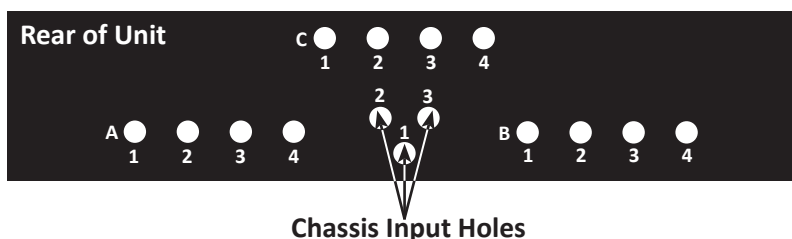
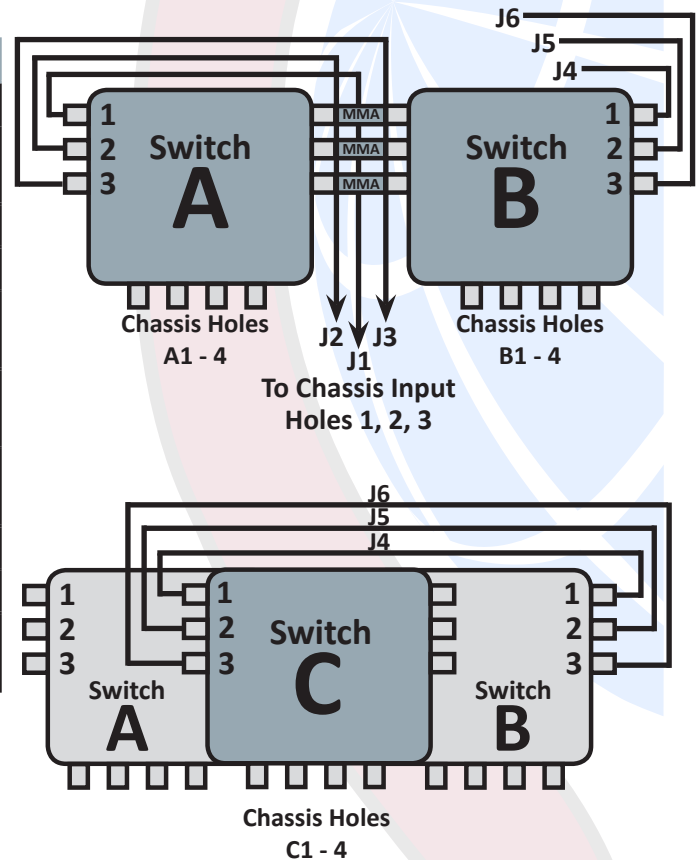

MUL-MS34-CH/K - Rack Mount Kit for three DP34s
MUL-MS34-CH/A - Three DP34s Assembled in Chassis

www.multicominc.com

Multicom, Inc.
Ph: 800-423-2594
Fax: 407-339-0204
Email: multicom@multicominc.com