

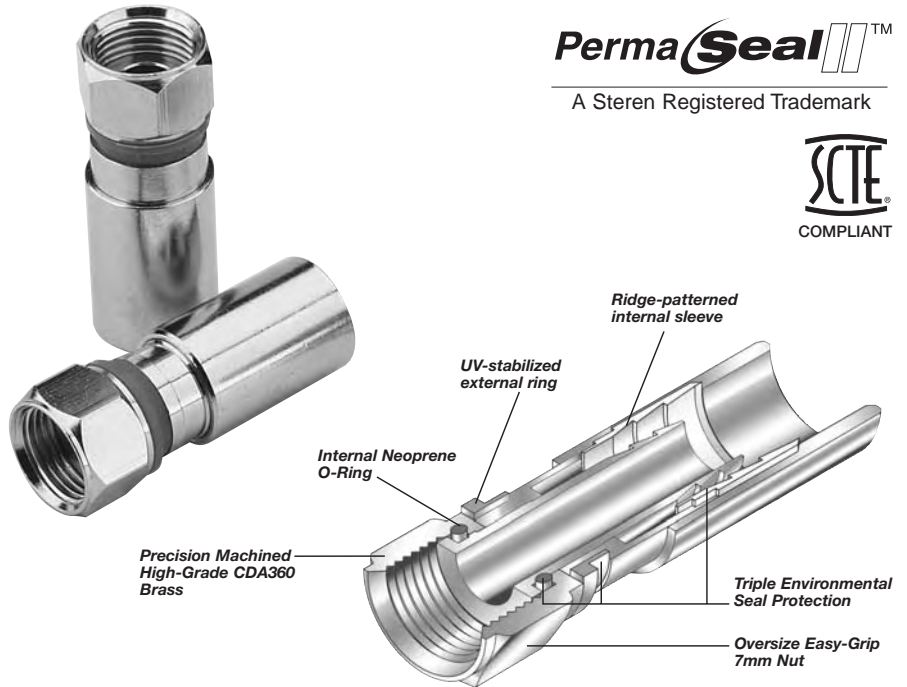

F-001 Series

PermaSeal-II™ F Series Compression Connectors

- ▶ **Single-piece elegant design simplifies installation and reduces assembly time**
- ▶ **Triple environment seal protection prevents (cable-to-connector interface) water migration providing fail-safe protection**
- ▶ **Internal Neoprene O-Ring and UV-stabilized external ring prevents water migration through the connector collar ensuring reliability and high performance**
- ▶ **Unique ridge-patterned internal sleeve presses connector securely against cable jacket providing positive mechanical restraint and permanent moisture migration seal**
- ▶ **Precision machined high-grade CDA360 brass construction, nickel or cadmium plated for maximum corrosion resistance**
- ▶ **70-lbs pull-out strength exceeds SCTE cable retention standard IPS-SP-405**
- ▶ **Impressive -30dB return loss typical up to 3GHz and less than -0.20dB insertion loss typical to 3GHz provides unsurpassed performance**
- ▶ **Higher than 96dB RFI shielding provided through true 360° internal radial compression**
- ▶ **Color-coded collar rings allow easy cable size identification**
- ▶ **Oversize easy-grip 7mm wide 7/16" hex free-spinning nut allows easy installation**
- ▶ **Quick 1/4"-1/4" standard cable preparation allows use with TruSpec™ PFC-001 or most other manufacturer's compression tools**



PermaSeal™

A Steren Registered Trademark

SCTE
COMPLIANT

F-001 Series

PermaSeal-II™ F Series Compression Connectors

The PermaSeal-II™ F-001 Series is Pico Macom's high-grade compression connector designed for use with standard, tri-shield, or quad-shield SCTE specification 59, 6, and 11 series cable. The patented true 360° internal compression design allows excellent RFI shielding properties while maintaining an impressive -30dB return loss to 3GHz. The PermaSeal-II™ provides triple protection against moisture migration ensuring high reliability and consistent performance. The internal O-Ring and UV-stabilized external ring fully seal the connector collar while a unique ridge-patterned internal sleeve presses firmly against the cable jacket sealing the connector against moisture at the back end. This same internal sleeve also provides over 70-lbs pulling strength, exceeding SCTE's cable retention standards without damage to the cable's outer jacket. PermaSeal-II™'s connector body is constructed of precision machined brass and nickel or cadmium coated providing superior resistance to corrosion. Its industry standard length allows use with TruSpec™ PFC-001 compression tool or most commercially available tools, making installation fast and reliable. Each connector is easily color-identified for cable size.

Order From:



Toll Free: 800-423-2594
www.multicominc.com
multicom@multicominc.com

F-001 Series

PermaSeal-II™ F Series Compression Connectors

Figure A

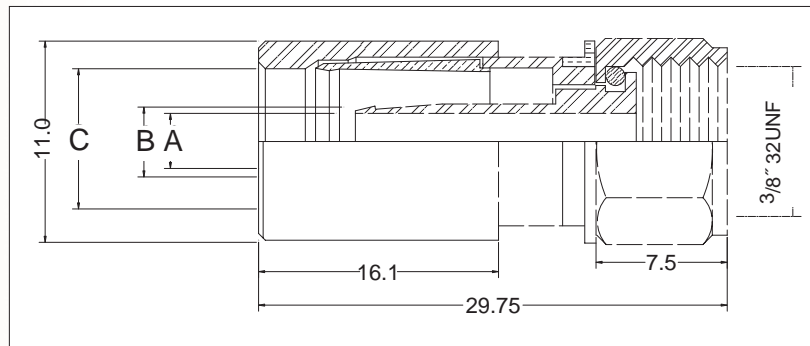
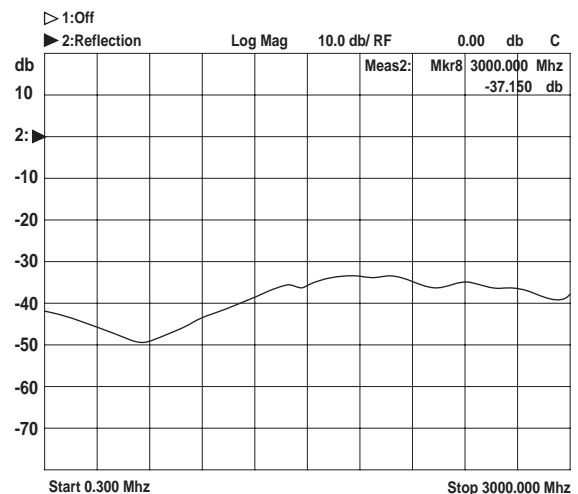

Figure B

Specifications

Nut:	CDA360 Brass
Internal O-Ring:	Rubber Neoprene
External O-Ring:	Nylon UV-Stabilized
Color Band:	PVC
Body:	CDA360 Brass
Center Ring:	CDA360 Brass
Compression Ring:	Nylon
Outer Body:	CDA360 Brass
Frequency range:	0-3 GHz
Impedance:	75 Ohms
Return Loss:	>-30 dB @ 1 GHz
Insertion Loss:	0.1 dB @ 1 GHz 0.3 dB @ 3 GHz
Crimp Tool:	TruSpec™ PFC-001

RETURN LOSS Typical



Ordering Information

F56-001	RG6 PermaSeal-II™ Yellow Band
F56Q-001	RG6-Quad PermaSeal-II™ Blue Band
F59-001	RG59 PermaSeal-II™ Red Band
F11-001	RG11 PermaSeal-II™

Dimensions (mm)			Figure
A	B	C	
4.8	5.5	8.0	A
4.8	5.5	8.5	A
8.2	7.3	11.3	B
3.9	4.6	7.0	A