

Product Overview

RUGGEDCOM RS950G

Managed PRP Redundancy Box

The RUGGEDCOM RS950G from Siemens is a platform to demonstrate RUGGEDCOM's on-going implementation of network redundancy as defined in the standard IEC 62439-3. The RS950G is a rugged fiber and copper universally deployable IEC 62439-4 Redundancy Box (RedBox), that supports both High Availability Seamless Redundancy (HSR) and Parallel Redundancy Protocol (PRP), and extends the life of legacy IEDs by connecting them to HSR/PRP networks.

Designed to operate reliably in harsh environments the RS950G provides a high level of immunity to electromagnetic interference and heavy electrical surges typical of environments found in electric utility substations, curb side traffic control cabinets, and factory floors. An operating temperature range of -40°C to +85°C coupled with hazardous location compliance (Class 1 Division 2), optional conformal coating and a galvanized steel enclosure allows the RS950G to be placed in almost any location.

PRP and HSR are two mechanisms defined by the IEC 62439-3 standard to provide hitless network recovery. PRP provides hitless network recovery by replicating information over two physically independent Ethernet networks. The basic principle behind HSR is the replication of frames over both sides of the HRS ring.

The RS950G provides the ultimate in network reliability and zero failover time from any network fault. This is achieved by simultaneously transmitting duplicate packets on independent routes through the network to provide complete path redundancy at the data link layer. The RS950G supports full HSR RedBox functionality as described in IEC62439-3, including generation of HSR supervision frames on behalf of Singly Attached Nodes (SANs). In PRP networks the receiving nodes eliminate redundant packets resulting in a truly seamless failover mechanism that is not compromised by failures.

All RUGGEDCOM products are backed by a five year warranty and unsurpassed technical support.





Features and benefits

Reliability

- IEC 62439-3 PRP
- Guaranteed behavior under failure conditions
- High availability network using simultaneous transmission over two Ethernet ports
- Efficient elimination of duplicated packets at hardware level
- Zero recovery time from network failures
- FPGA implementation maximizes PRP performance

Ethernet Ports

- 3 configurable copper or fiber ports
 - 2 IEC 62439 Ethernet ports (HSR or PRP)
 - 1 Access port for standard IEEE 802.3 Ethernet devices
- SFP pluggable fiber transceiver with 100FX or 1000LX/SX options
- 3 X 10/100/1000 BaseT copper ports (disabled when SFP present)
- RS232 Console Port
- Up to 70km with long-haul optics
- LED Status Indicators

Cyber Security Features

- Multi-level user passwords
- SSH/SSL (128-bit encryption)
- Enable/disable ports, MAC based port security
- SSL web based management with data encryption
- RADIUS centralized password management
- SNMPv3 authentication and 56-bit encryption

Precision Timing

- IEEE 1588 v2 with hardware time stamping on all ports
- Transparent clock operation

Rugged Rated for Reliability in Harsh Environments

- Immunity to EMI and heavy electrical surges
 - IEC 62439-3 PRP
 - Meets IEEE 1613 (electric utility substations)
 - Exceeds IEC 61850-3 (electric utility substations)
- -40°C to +85°C operating temperature
- No moving parts
- Conformal coated printed circuit boards (optional)

Management Tools

- Web-based, Telnet, CLI management interfaces
- SNMP v1/v2/v3 (56-bit encryption)
- Remote monitoring (RMON)
- Rich set of diagnostics with logging and alarms
- IEC 62439 MIB Support

Universal Power Supply Options

- Fully integrated power supply (no external adaptors)
- Popular low-voltage DC ranges: 24VDC (10-36VDC) or 48VDC (36-72VDC)
- Universal high-voltage range: 88-300VDC or 85-264VAC
- CSA/UL 60950 safety approved to +85°C
- Screw connection terminal blocks ensure reliable maintenance free connections



RUGGEDCOM RS950G

Dual Ports (Fiber or Copper)

Fiber:

- ▶ Pluggable Optics (SFP)
- ▶ LC connectors

Copper:

- ▶ 100TX/RJ45

Operating Temperature

- ▶ -40°C to +85°C
- ▶ No fans

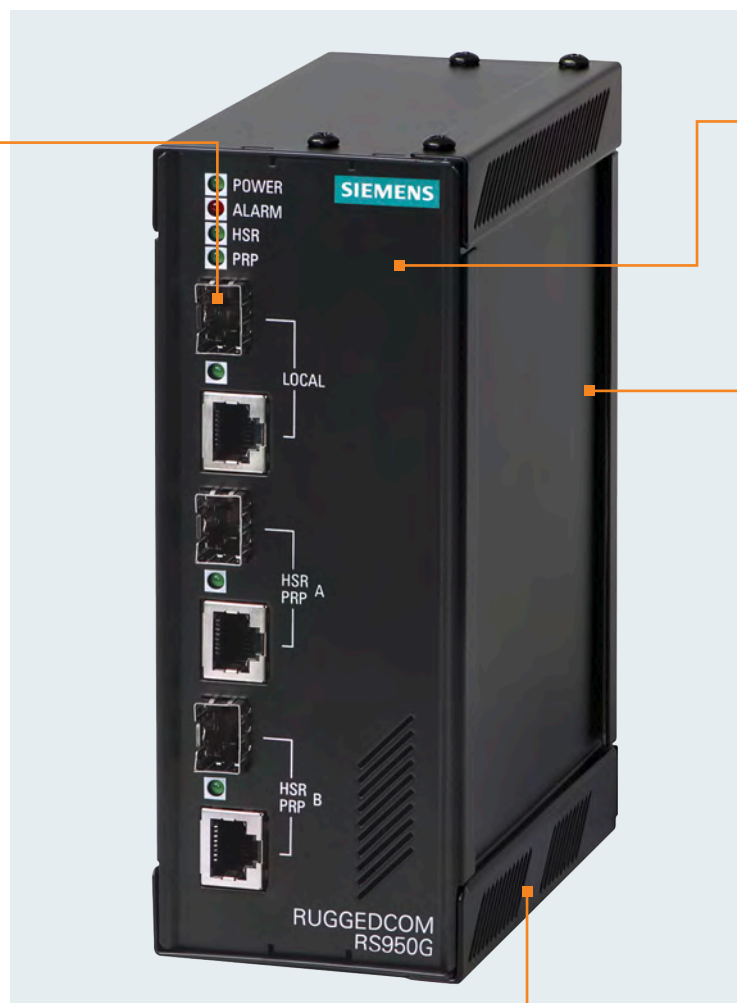

Power Inputs

- ▶ 24 VDC (10-36 VDC)
- ▶ 48 VDC (36-72 VDC)
- ▶ 85-264VAC or 88-300VDC

Rugged Construction

- ▶ 20 AWG galvanized steel enclosure
- ▶ Conformal coating (optional)

Critical Alarm Relay

- ▶ Form-C failsafe contact relay: 1A@30VDC

Mounting Options

- ▶ DIN rail
- ▶ Panel mount

Parallel Redundancy Protocol (PRP)

Benefits

- Connects legacy non-PRP devices to high availability IEC 62439 networks
- Delivers unprecedented reliability, resilience to faults and performance for the most critical applications
- Allows scalability by supporting multiple network topologies, eg: tree, ring, mesh, etc.

Applications

- Substation automation networks compliant to IEC 61850
- Reliable circuit breaker tripping via GOOSE
- Guaranteed delivery of sampled measured values (SMV) on IEC 61850-9-2 process bus
- High availability industrial control networks with zero failover time
- Time-critical and Safety-critical transport systems

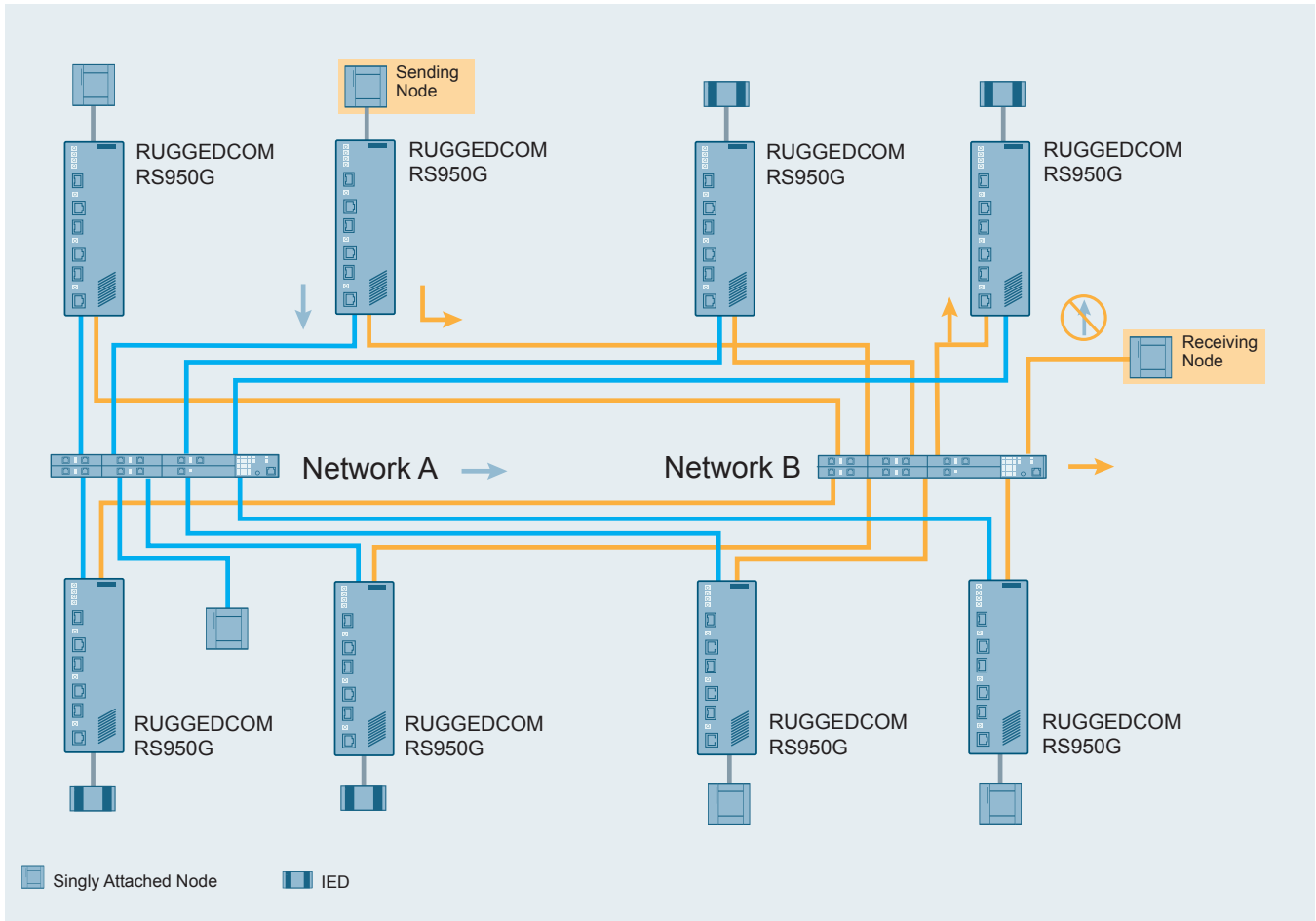

The RS950G can be used in PRP mode. Duplicate packets are generated by the sending node and removed at the receiving node as required. With PRP, singly attached nodes can be part of the network.

ROS Features

Parallel Redundancy Protocol (PRP)

The RuggedCom RS950G is compliant with IEC 62439 and PRP. The RS950G generates duplicate packets and transmits them on independent paths on the PRP networks, providing complete redundancy for network or device faults that could interrupt the continued operation. If both paths remain intact and the receiving node receives duplicate packets, the RS950G ensures the duplicate packets are removed and taken out of circulation. The RS950G permits connection of singly attached nodes to the PRP networks.

Cyber Security

- Passwords – Multilevel user passwords secure switch against unauthorized configuration
- SSH / SSL – Extends capability of password protection to add 128-bit encryption of passwords and data as they cross the network
- MAC-based port security – Ability to secure ports on a switch so only specific devices / MAC addresses can communicate via that port
- RADIUS – Authentication service using MD5 hash and providing centralized password management
- SNMPv3 – Encrypted authentication access security and data encryption (CBC-DES with 56-bit encryption key)
- Secure Sockets Layer – Web-based management using SSL with data encryption (128-bit encryption key)

SNMP (Simple Network Management Protocol)

SNMP provides a standardized method for network management stations to interrogate devices from different vendors. SNMPv3 in particular provides security features such as authentication, privacy with data encryption (CBC-DES with 56-bit encryption key) and access control not present in earlier SNMP versions. ROS also supports numerous standard MIBs (Management Information Base) allowing for easy integration with any network management system (NMS).

A feature of SNMP supported by ROS is the ability to generate “traps” upon system events. RUGGEDCOM NMS, the RUGGEDCOM management solution, can record traps from multiple devices providing a powerful network troubleshooting tool. It also provides a graphical visualization of the network and is fully integrated with all RUGGEDCOM products.

SNTP (Simple Network Time Protocol)

SNTP automatically synchronizes the internal clock of all ROS devices on the network. This allows for correlation of time stamped events for troubleshooting.

Loss of Link Management

Some intelligent electronic devices (IEDs) have dual fiber optic ports with automatic failover to a backup port should the primary fail. ROS ensures this mechanism works reliably under all failure modes by appropriately disabling link signals when required. ROS also flushes learned MAC addresses to ensure the failover occurs quickly.

Port Statistics and RMON (Remote Monitoring)

ROS provides continuously updating statistics per port that provide both ingress and egress packet and byte counters as well as detailed error figures. Also provided is full support for the RMON statistics, history, alarms, and event groups. RMON allows for very sophisticated data collection, analysis and detection of traffic patterns.

Event Logging and Alarms

ROS records all significant events to a non-volatile system log allowing forensic troubleshooting. Events include link failure and recovery, unauthorized access, broadcast storm detection, and self-test diagnostics among others. Alarms provide a snapshot of recent events that have yet to be acknowledged by the network administrator. An external hardware relay is de-energized during the presence of critical alarms allowing an external controller to react if desired.

HTML Web Browser and Telnet/SSH User Interfaces

ROS provides a simple, intuitive user interface for configuration and monitoring via a standard graphical web browser or via Telnet/SSH. All system parameters include detailed on-line help to make setup a breeze. ROS, presents a common look and feel and standardized configuration process allowing easy migration to other RUGGEDCOM managed products.

Configuration via ASCII Text File

All configuration parameters are stored in an ASCII formatted text file that can easily be transferred via TFTP, SFTP or Xmodem. The configuration file can be saved for backup purposes and easily manipulated by a text editor. The same text file can be downloaded to the switch at a later date in order to re-configure or restore a previous configuration.

Command Line Interface (CLI)

A command line interface can be used in conjunction with remote shell to automate data retrieval, configuration updates, and firmware upgrades. A powerful SQL-like capability allows expert users the ability to selectively retrieve or manipulate any parameters the device has to offer.

EMI and Environmental Type Tests

IEC 61850-3 EMI Type Tests				
Test	Description		Test Levels	Severity Levels
IEC 61000-4-2	ESD	Enclosure contact	+/- 8kV	4
		Enclosure air	+/- 15kV	4
IEC 61000-4-3	Radiated RFI	Enclosure ports	20 V/m	x
IEC 61000-4-4	Burst (fast transient)	Signal ports	+/- 4kV @ 2.5kHz	x
		D.C. power ports	+/- 4kV	4
		A.C. power ports	+/- 4kV	4
		Earth ground ports ³	+/- 4kV	4
IEC 61000-4-5	Surge	Signal ports	+/- 4kV line-to-earth, +/- 2kV line-to-line	4
		D.C. power ports	+/- 2kV line-to-earth, +/- 1kV line-to-line	3
		A.C. power ports	+/- 4kV line-to-earth, +/- 2kV line-to-line	4
IEC 61000-4-6	Induced (conducted) RFI	Signal ports	10V	3
		D.C power ports	10V	3
		A.C. power ports	10V	3
		Earth ground ports ³	10V	3
IEC 61000-4-8	Magnetic field	Enclosure ports	40 A/m continuous, 1000 A/m for 1 s	N/A
			1000 A/m for 1 s	N/A
IEC 61000-4-29	Voltage dips and interrupts	D.C. power ports	30% for 0.1s, 60% for 0.1s, 100% for 0.05s	N/A
IEC 61000-4-11		A.C. power ports	30% for 1 period, 60% for 50 periods	N/A
IEC 61000-4-12	Damped oscillatory	Signal ports	2.5kV common, 1kV diff. mode@1MHz	3
		D.C. power ports	2.5kV common, 1kV diff. mode@1MHz	3
		A.C. power ports	2.5kV common, 1kV diff. mode@1MHz	3
IEC 61000-4-16	Mains frequency voltage	Signal ports	30V Continuous, 300V for 1s	4
		D.C. power ports	30V Continuous, 300V for 1s	4
IEC 61000-4-17	Ripple on D.C. power supply	D.C. power ports	10%	3
IEC 60255-5	Dielectric strength	Signal ports	2kVac (Fail-safe relay output)	N/A
		D.C. power ports	1.5V DC	N/A
		A.C. power ports	2kVac	N/A
IEC 60255-5	H.V. Impulse	Signal ports	5kV (Fail-safe relay output)	N/A
		D.C. Power ports	5kV	N/A
		A.C. Power ports	5kV	N/A

IEEE 1613 (C37.90.x) EMI immunity Type Tests				
Test	Description		Test Levels	Severity Levels
IEEE C37.90.3	ESD	Enclosure contact	+/- 8kV	N/A
		Enclosure air	+/-15kV	N/A
IEEE C37.90.2	Radiated RFI	Enclosure ports	35 V/m	N/A
IEEE C37.90.1	Fast transient	Signal ports	+/- 4kV @ 2.5kHz	N/A
		D.C. power ports	+/- 4kV	N/A
		A.C. power ports	+/- 4kV	N/A
		Earth ground ports ³	+/- 4kV	N/A
IEEE C37.90.1	Oscillatory	Signal ports	2.5kV common mode@1MHz	N/A
		D.C. power ports	2.5kV common, 1kV diff. mode@1MHz	N/A
		A.C. power ports	2.5kV common, 1kV diff. mode@1MHz	N/A
IEEE C37.90	H.V. impulse	Signal ports	5kV (Fail-safe relay output)	N/A
		D.C. power ports	5kV	N/A
		A.C. power ports	5kV	N/A
IEEE C37.90.	Dielectric strength	Signal ports	2kVac	N/A
		D.C. power ports	1.5kVac	N/A
		A.C. power ports	2kVac	N/A

Environmental Type Tests				
Test	Description		Test Levels	Severity Levels
IEC 60068-2-1	Cold temperature	Test Ad	-40°C, 16 hours	N/A
IEC 60068-2-2	Dry heat	Test Bd	+85°C, 16 hours	N/A
IEC 60068-2-30	Humidity (damp heat, cyclic)	Test Db	95% (non-condensing), 55°C , 6 cycles	N/A
IEC 60255-21-1	Vibration	Test Fc	2g @ (10 - 150) Hz	Class 2 ²
IEC 60255-21-2	Shock	Test Ea	30g @ 11mS	Class 2 ²

¹ RUGGEDCOM specified severity levels.

² Class 2 refers to "Measuring relays and protection equipment for which a very high security margin is required or where the vibration levels are very high, (e.g. shipboard application and for severe transportation conditions)".

³ Only applicable to functional earth connections separated from the safety earth connection.

Technical Specifications

Interfaces

- Two IEC 62439 PRP Ethernet ports
- One access port for standard IEEE 802.3 Ethernet devices
- All Ethernet ports support copper or fiber media
 - SFP pluggable fiber transceiver with 100FX
 - 100TX (disabled when SFP present)
- RS232 Console Port
- LED Status Indicators

Power

- Dual DC inputs
- Power Consumption: 10W Max
- 24VDC: 10-36 VDC, 1.2A
- 48VDC: 36-72 VDC, 0.6A
- HI Voltage AC/DC: 88-300VDC or 85-264VAC

Critical Alarm Relay

- Form-C contact relay:
 - Max Voltage 250VAC, 125VDC
 - Max Current 2A@250VAC, 2A@30VDC

Environmental

- -40 to +85C (operating and storage) (no fans)
- 5 to 95% relative humidity (non-condensing)

Physical Dimensions

- Height: 7.4" (188mm)
- Width: 2.6" (66mm)
- Depth: 5.0" (127mm)
- Weight: 1.22kg
- Ingress Protection: IP40 (1mm objects)
- Enclosure: 20 AWG galvanized steel enclosure
- Mounting: DIN rail or panel mounted

Switch Properties

- MAC addresses: 1024
- Frame buffer memory: 512k bits

Regulatory Approvals

- ISO: Designed and manufactured using an ISO9001: 2000 certified quality program
- CE marking
- Emissions: FCC Part 15 (Class A), EN55022 (CISPR22 Class A)
- Safety: cCSAus (Compliant with CSA C22.2 No. 60950, UL 60950, EN60950)
- Laser eye safety (FDA/CDRH): Complies with 21 CFR Chapter 1, Subchapter J

Network Management

- HTTPS graphical web-based
- Telnet, VT100
- Command Line Interface (CLI)
- SSH/SFTP (128-bit encryption)
 - SNMP v1, v2c, v3 (56-bit encryption)
 - Authentication and Accounting - TACACS+
 - RADIUS client

Warranty

- 5 Years – Applicable to design and manufacturing related product defects.

EMI Immunity and Environmental Compliance

- IEC 61000-6-2 Industrial (Generic)
- IEC 61800-3 Industrial (Variable Speed Drive Systems)
- IEC 61850-3 Electric Utility Substations
- IEEE 1613 Electric Utility Substations
- Hazardous Locations: Class 1, Division 2

IEEE Compliance

- 802.3u-100BaseTX, 100BaseFX

IETF RFC Compliance

- RFC768-UDP
- RFC783-TFTP
- RFC791-IP
- RFC792-ICMP
- RFC793-TCP
- RFC826-ARP
- RFC854-Telnet
- RFC894-IP over Ethernet
- RFC2865-RADIUS
- RFC1519-CIDR
- RFC1541-DHCP (client)
- RFC2030-SNTP
- RFC2068-HTTP

IETF SNMP MIBS

- RFC1493-BRIDGE-MIB
- RFC1907-SNMPv2-MIB
- RFC2012-TCP-MIB
- RFC2013-UDP-MIB
- RFC2578-SNMPv2-SMI
- RFC2579-SNMPv2-TC
- RFC2863-IF-MIB
- IANAifType-MIB