



The RuggedServer™ RMC30 is an industrially hardened, 2-port Serial-to-Ethernet server that has been specifically designed to operate in electrically harsh and climatically demanding environments. The RMC30 allows you to communicate with virtually any serial device via Ethernet providing simple and reliable network connectivity.

The RMC30 is packaged in a compact, galvanized steel enclosure that allows either DIN or panel mounting for efficient use of cabinet space. It has an integrated power supply with a wide range of voltages for worldwide operability. An operating temperature range of -40 to +85°C (-40 to +185°F) without the use of internal cooling fans allows it to be placed in almost any location. The RMC30 is compliant with EMI and environmental standards for utility substations, industrial manufacturing, process and control and intelligent transportation systems applications.

The RMC30 offers both an RS232 port and a RS485/422 port simultaneously via a solid screw down terminal block. The 10Base-T Ethernet port supports both auto-negotiation and auto-crossover detection and simplifies cabling. Simple and intuitive network based configuration using either the built in Web or Telnet server makes setup a breeze.

The RMC30's superior ruggedized design coupled with the Rugged Operating System™ (ROS®) provides improved system reliability making it ideally suited for creating Ethernet networks for mission critical, real-time, control applications.

All RuggedCom products are backed by a five year warranty and unsurpassed technical support.

Features and Benefits

Connectivity

- 1-RS232 and 1-RS422/485 port
- 1-10BaseTX
- Fully compliant EIA/TIA RS485 and RS232 ports
- Built-In optional RS485 Termination

Serial Encapsulation

- Transmit serial data over an IP network
- Support for Modbus TCP, DNP 3, TIN serial protocols
- Baud rates up to 230 kbps
- Point to point and multi-point modes
- Convert Modbus RTU to Modbus TCP
- Support multiple Modbus masters
- Use 'Serial IP' port redirection software to support PC applications statistics and built-in 'sniffer' for troubleshooting

Universal Power Supply Options

- Input voltages of 24VDC, 48VDC, HI = (88-300VDC or 85-264VAC) for worldwide operability
- Integrated power supply eliminates need for an awkward external power transformer
- Screw down terminal blocks ensure reliable maintenance free connections
- CSA/UL 60950 safety approved to +85°C

Designed for Harsh Environments

- Exceeds IEC 61850-3 requirements for electric power substations
- Exceeds IEC 61000-6-2 for industrial environments
- Exceeds NEMA TS 2 requirements for traffic control equipment
- Meets IEEE 1613 requirements for electric power substations
- 3kV (RMS) Isolated serial ports
- Operates over a temperature range of -40°C to +85°C without the use of fans for improved reliability
- 21 AWG galvanized steel enclosure and DIN or panel mounting options provide secure mechanical reliability

Management and Diagnostics

- Web-based, Telnet, CLI management interfaces
- SNMP v1/v2/v3 with traps (56-bit encryption)
- Rich set of diagnostics with logging and alarms
- Ethernet and Serial LED indicators aid in field troubleshooting
- Flash memory for easy upgrades
- System watchdog with automatic reset
- Built in real time clock and SNTP time synchronization

Ethernet Management Features

Rugged Operating System™ (ROS®)

The RMC30 includes a subset of the features of the industry leading Rugged Operating System™ (ROS®), RuggedCom's embedded Operating System for network devices.

Serial IP Encapsulation

Many 'legacy' devices (RTU, PLC, IED, etc.) only support serial communications via RS232. The RMC30 encapsulates the serial data within a TCP connection allowing these devices to be reached via an IP network. A wide range of baud rates, frame packetization options, and diagnostics allows any serial protocol to function. The RMC30 has specific support for the following serial protocols:

- Raw Socket serial encapsulation
- Modbus TCP (client and server)
- DNP 3
- WIN and TIN
- Microlok

MODBUS TCP

The Modbus protocol is ubiquitous in the industrial control and automation world. The RMC30 converts ModbusRTU master/slave serial data packets to Modbus TCP client/server packets for transmission over an IP network. This allows communications to Modbus RTU slaves via Ethernet and allows multiple masters to poll the same slave device.

SNMP (Simple Network Management Protocol)

SNMP provides a standardized method for network management stations the ability to interrogate devices from different vendors. SNMP versions supported by ROS® are v1, v2c, and v3. SNMPv3 in particular provides security features such as authentication, privacy with data encryption (CBC-DES with 56-bit encryption key) and access control not present in earlier SNMP versions. ROS® supports numerous standard MIBs (Management Information Base) allowing for easy integration with any network management system (NMS). A feature of SNMP supported by ROS® is the ability to generate "traps" upon system events. RuggedNMS™, the RuggedCom management solution, can record traps from multiple devices providing a powerful network troubleshooting tool. It also provides a graphical visualization of the network and is fully integrated with all RuggedCom products.

HTML Web Browser and Telnet User Interfaces

ROS® provides a simple, intuitive user interface for configuration and monitoring via a standard graphical web browser or via Telnet. All system parameters include detailed on-line help to make setup a breeze. ROS®, presents a common look and feel and standardized configuration process allowing easy migration to other RuggedCom managed products.

Event Logging and Alarms

ROS® records all significant events to a non-volatile system log allowing forensic troubleshooting. Events include link failure and recovery, unauthorized access, broadcast storm detection, and self-test diagnostics among others. Alarms provide a snapshot of recent events that have yet to be acknowledged by the network administrator. An extreme hardware relay is de-energized during the presence of critical alarms allowing an external controller to react if desired.

SNTP (Simple Network Time Protocol)

SNTP automatically synchronizes the internal clock of all ROS® devices on the network. This allows for correlation of time stamped events for troubleshooting.

Configuration via ASCII Text File

All configuration parameters are stored in an ASCII formatted text file that can easily be transferred via TFTP or Xmodem. The configuration file can be saved for backup purposes and easily manipulated by a text editor. The text same file can be downloaded to the switch at a later date in order to re-configure or restore a previous configuration.

Command Line Interface (CLI)

A command line interface can be used in conjunction with remote shell to automate data retrieval, configuration updates, and firmware upgrades. A powerful SQL-like capability allows expert users the ability to selectively retrieve or manipulate any parameters the device has to offer.

EMI and Environmental Type Tests

| IEC 61850-3 EMI TYPE TESTS | | | | |
|----------------------------|-----------------------------|---------------------------------|--|-----------------|
| TEST | Description | | Test Levels | Severity Levels |
| IEC 61000-4-2 | ESD | Enclosure Contact | +/- 8kV | 4 |
| | | Enclosure Air | +/- 15kV | 4 |
| IEC 61000-4-3 | Radiated RFI | Enclosure ports | 20 V/m | x |
| IEC 61000-4-4 | Burst (Fast Transient) | Signal ports | +/- 4kV @ 2.5kHz | x |
| | | D.C. Power ports | +/- 4kV | 4 |
| | | A.C. Power ports | +/- 4kV | 4 |
| | | Earth ground ports ³ | +/- 4kV | 4 |
| IEC 61000-4-5 | Surge | Signal ports | +/- 4kV line-to-earth, +/- 2kV line-to-line | 4 |
| | | D.C. Power ports | +/- 2kV line-to-earth, +/- 1kV line-to-line | 3 |
| | | A.C. Power ports | +/- 4kV line-to-earth, +/- 2kV line-to-line | 4 |
| IEC 61000-4-6 | Induced (Conducted) RFI | Signal ports | 10V | 3 |
| | | D.C Power ports | 10V | 3 |
| | | A.C. Power ports | 10V | 3 |
| | | Earth ground ports ³ | 10V | 3 |
| IEC 61000-4-8 | Magnetic Field | Enclosure ports | 40 A/m continuous, 1000 A/m for 1 s | N/A |
| IEC 61000-4-29 | Voltage Dips & Interrupts | D.C. Power ports | 30% for 0.1s, 60% for 0.1s, 100% for 0.05s | N/A |
| IEC 61000-4-11 | | A.C. Power ports | 30% for 1 period, 60% for 50 periods | N/A |
| | | | 100% for 5 periods, 100% for 50 periods ² | N/A |
| IEC 61000-4-12 | Damped Oscillatory | Signal ports | 2.5kV common, 1kV diff. mode@1MHz | 3 |
| | | D.C. Power ports | 2.5kV common, 1kV diff. mode@1MHz | 3 |
| | | A.C. Power ports | 2.5kV common, 1kV diff. mode@1MHz | 3 |
| IEC 61000-4-16 | Mains Frequency Voltage | Signal ports | 30V Continuous, 300V for 1s | 4 |
| | | D.C. Power ports | 30V Continuous, 300V for 1s | 4 |
| IEC 61000-4-17 | Ripple on D.C. Power Supply | D.C. Power ports | 10% | 3 |
| IEC 60255-5 | Dielectric Strength | Signal ports | 2kVac (Fail-Safe Relay output) | N/A |
| | | D.C. Power ports | 1.5kV DC | N/A |
| | | A.C. Power ports | 2kVac | N/A |
| IEC 60255-5 | H.V. Impulse | Signal ports | 5kV (Fail-Safe Relay output) | N/A |
| | | D.C. Power ports | 5kV | N/A |
| | | A.C. Power ports | 5kV | N/A |

| IEEE 1613 (C37.90.x) EMI IMMUNITY TYPE TESTS | | | | |
|--|---------------------|---------------------------------|-----------------------------------|-----------------|
| Test | Description | | Test Levels | Severity Levels |
| IEEE C37.90.3 | ESD | Enclosure Contact | +/- 8kV | N/A |
| | | Enclosure Air | +/- 15kV | N/A |
| IEEE C37.90.2 | Radiated RFI | Enclosure ports | 35 V/m | N/A |
| IEEE C37.90.1 | Fast Transient | Signal ports | +/- 4kV @ 2.5kHz | N/A |
| | | D.C. Power ports | +/- 4kV | N/A |
| | | A.C. Power ports | +/- 4kV | N/A |
| | | Earth ground ports ³ | +/- 4kV | N/A |
| IEEE C37.90.1 | Oscillatory | Signal ports | 2.5kV common mode @1MHz | N/A |
| | | D.C. Power ports | 2.5kV common, 1kV diff. mode@1MHz | N/A |
| | | A.C. Power ports | 2.5kV common, 1kV diff. mode@1MHz | N/A |
| IEEE C37.90 | H.V. Impulse | Signal ports | 5kV (Fail-Safe Relay output) | N/A |
| | | D.C. Power ports | 5kV | N/A |
| | | A.C. Power ports | 5kV | N/A |
| IEEE C37.90 | Dielectric Strength | Signal ports | 2kVac | N/A |
| | | D.C. Power ports | 1.5kV DC | N/A |
| | | A.C. Power ports | 2kVac | N/A |

| Environmental Type Tests | | | | |
|--------------------------|------------------------------|----------|--------------------------------------|-----------------|
| Test | Description | | Test Levels | Severity Levels |
| IEC 60068-2-1 | Cold Temperature | Test Ad | -40°C, 16 Hours | N/A |
| IEC 60068-2-2 | Dry Heat | Test Bd | +85°C, 16 Hours | N/A |
| IEC 60068-2-30 | Humidity (Damp Heat, Cyclic) | Test Db | 95% (non-condensing), 55°C, 6 cycles | N/A |
| IEC 60255-21-1 | Vibration | Tests Fc | 2g @ (10 - 150) Hz | Class 2 |
| IEC 60255-21-2 | Shock | Tests Ea | 30g @ 11mS | Class 2 |

Notes: 1. Only applicable to functional earth connections separated from the safety earth connection.
2. Class 2 refers to "Measuring relays and protection equipment for which a very high security margin is required or where the vibration levels are very high, (e.g. shipboard application and for severe transportation conditions")

Typical Application

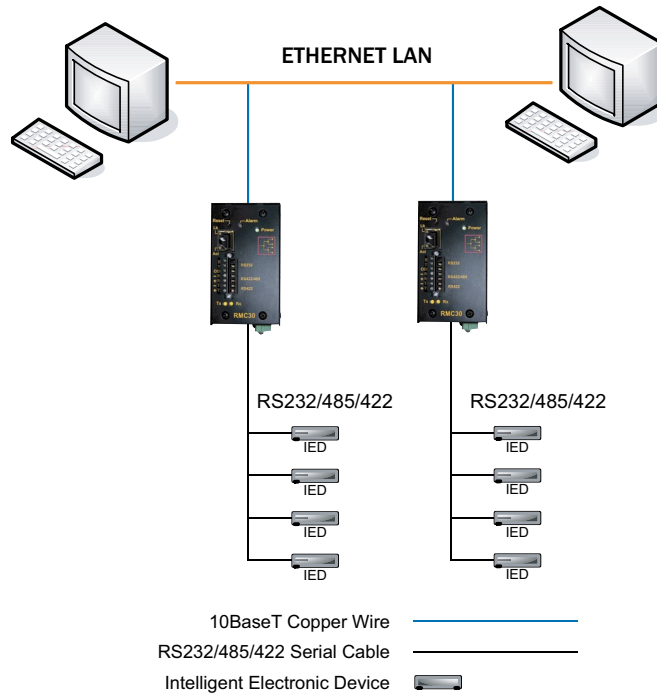

Dimensions

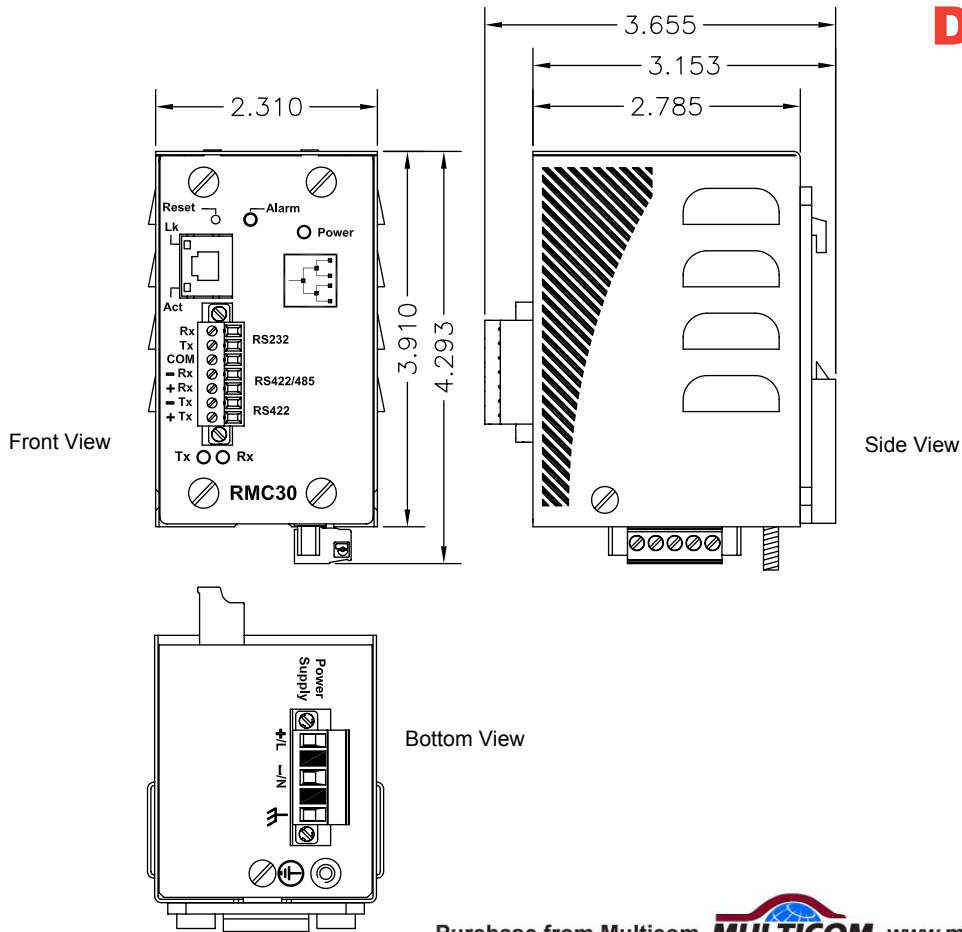

Technical Specifications

Power Supply

- Power Consumption: 2W (max)
- 24VDC: 18-36VDC (max)
- 48VDC: 36-59VDC (max)
- HI Voltage AC/DC: (88VDC-300VDC / 85VAC-264VAC) (max)

Physical

- Height: 4.3" / 10.9 cm
- Width: 2.3" / 5.8 cm
- Depth: 3.7" / 9.4 cm
- Weight: 1.5lbs (0.68kg)
- Ingress Protection: IP40 (1mm objects)
- Enclosure: 21 AWG galvanized steel enclosure
- Mounting: DIN rail or panel mounted

Network Management

- HTTP graphical web-based, SSL (128-bit encryption)
- SNMP v1, v2c, v3 (56-bit encryption)
- Telnet, VT100, SSH/SFTP (128-bit encryption)
- Command Line Interface (CLI)
- RSA Key Management (1024 bit key)
- Authentication and Accounting - TACACS+ (encrypted), RADIUS client, PPP

EMI Immunity and Environmental Compliance

- IEC 61000-6-2 Industrial (Generic)
- IEC 61800-3 Industrial (Variable Speed Drive Systems)
- IEC 61850-3 Electric Utility Substations
- IEEE 1613 Electric Utility Substations
- NEMA TS 2 Traffic Control Equipment

IETF RFC Compliance

- 802.3-10BaseT
- 802.3x-Flow Control

IEEE Compliance

- RFC791-IP
- RFC792-ICMP
- RFC793-TCP
- RFC783-TFTP
- RFC826-ARP
- RFC768-UDP
- RFC894-IP over Ethernet
- RFC854-Telnet
- RFC1519-CIDR

- RFC1541-DHCP (client)
- RFC2030-SNTP
- RFC2068-HTTP

IETF SNMP MIBS

- RFC791-IP
- RFC792-ICMP
- RFC793-TCP
- RFC783-TFTP
- RFC826-ARP
- RFC768-UDP
- RFC894-IP over Ethernet
- RFC854-Telnet
- RFC1519-CIDR
- RFC1541-DHCP (client)
- RFC2030-SNTP
- RFC2068-HTTP

Approvals

- ISO: Designed and manufactured using a ISO9001: 2000 certified quality program
- CE Marking
- Emissions: FCC Part 15 (Class A), N55022 (CISPR22 Class A)
- Safety: cCSAus (Compliant with CSA C22.2 No. 60950, UL 60950, EN60950)
- Laser Eye Safety (FDA/CDRH): Complies with 21 CFR Chapter1, Subchapter J.

Warranty

- 5 Years-Applicable to design or manufacturing related product defects.

Order Codes

RMC30 - -
 PS MOD

PS: Power Supply

- 24 = 24VDC (18-36VDC)
- 48 = 48 VDC (36-59VDC)
- HI = 88-300VDC or 85-264VAC

MOD: Manufacturing Modifications

- XX = None
- C01 = Conformal Coating

Mounting Options

- DIN rail mounting is standard
- For Panel mounting, order P/N 41-12-006